

Inline Exhibit

Definition

An exhibit with neighbouring exhibits on each side and faces only one main aisle.

Standard Exhibit Height

All display material over 4' high, placed within 10' of a neighbouring exhibit, must be set back 5' from the main aisle.

Intent

Each exhibitor is entitled to a reasonable sightline from the aisle regardless of the size of the exhibit. Exhibitors with larger space (30 linear feet or more) should be able to effectively use as much of the total floor space as possible so long as they do not interfere with the rights of others. The limitation on display fixtures over 4' within 10 linear feet of a neighboring exhibit is intended to accomplish this.

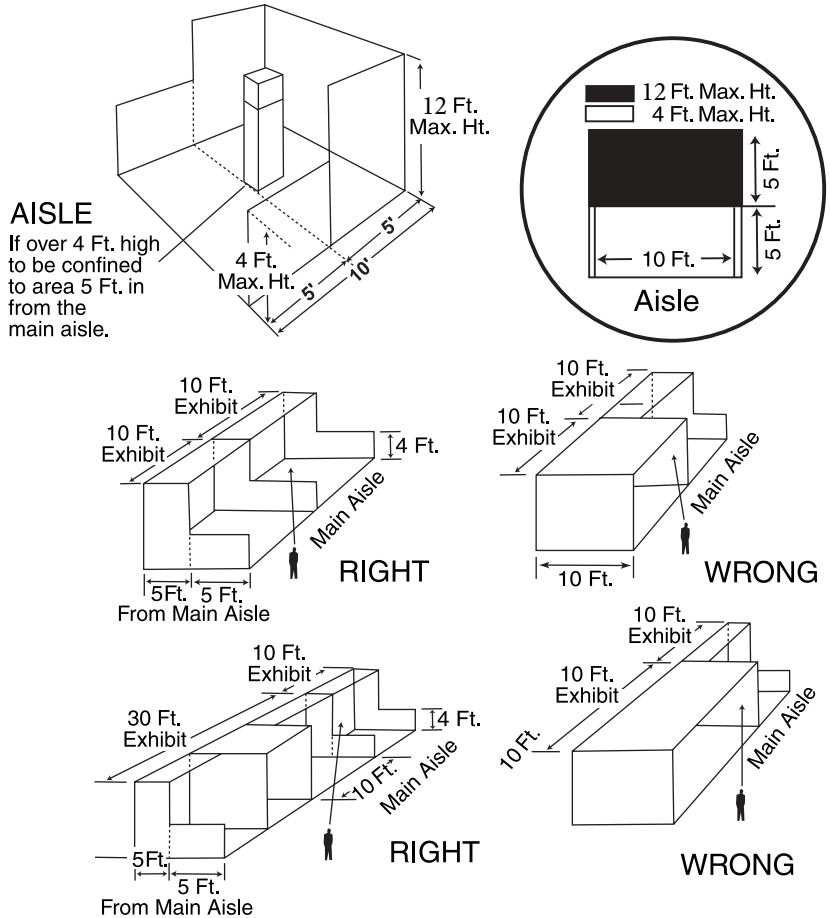

Show rules and regulations are intended to provide guidelines to insure all exhibitors have fair and equal opportunities to market their products and services. A violation of rules will result in show management requiring the exhibitor to modify their exhibit to conform to advertised regulations. Expenses incurred to rectify a violation are the responsibility of the exhibitor.

Corner Exhibit

Definition

A standard inline exhibit with at least 20' of main aisle frontage with an adjoining neighbouring exhibit on one side and a cross aisle on the other.

Corner Exhibit Height

All display materials over 4' high, within 10' of the neighbouring common side, must be placed 5' in from the main aisle.

Intent

Exhibitors adjoining corner exhibits are entitled to the same reasonable sightline from the aisle as if they were not next to a corner exhibit.

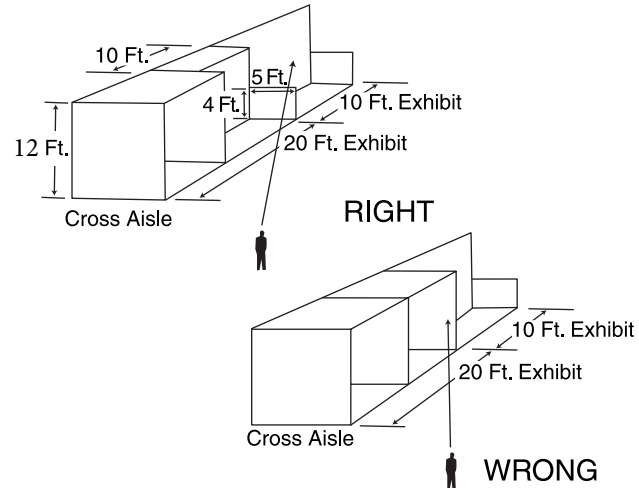

Towers

If your exhibit includes towers with verbiage facing a neighbour or other display material (signs, balloons), over 8' tall, they must be placed at least 5' from the border between your booth and your neighbour.

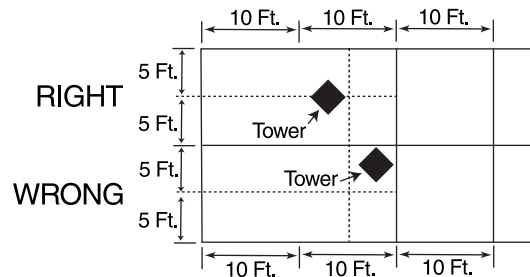

Show rules and regulations are intended to provide guidelines to insure all exhibitors have fair and equal opportunities to market their products and services. A violation of rules will result in show management requiring the exhibitor to modify their exhibit to conform to advertised regulations. Expenses incurred to rectify a violation are the responsibility of the exhibitor.

Peninsula Exhibit

Definition

An exhibit with three open sides, two sides on the main aisle and one side on a cross aisle.

Peninsula Exhibit Height

This type of exhibit must limit the length of backwall and placement of all displays over 4' high to 5' from the main traffic aisle (centered in the exhibit) and 10' from the neighbouring exhibit. These items must be set back 5' from the main aisle and 10' from the border of the neighbouring exhibit.

Intent

Exhibitors adjoining peninsula exhibits are entitled to the same reasonable sightline from the aisle as they would expect if they were adjacent to an exhibitor with a standard exhibit.

Curtains & Drapes

Exhibitors will not be allowed to place 15' high blocking curtains or side blocking unattractive displays along main traffic aisles.

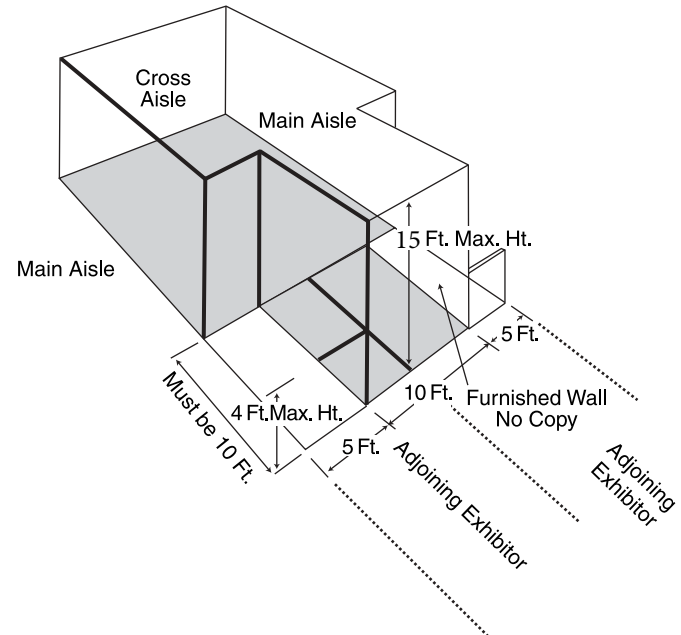
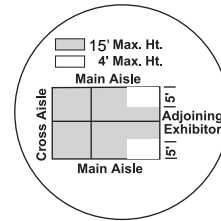

Show rules and regulations are intended to provide guidelines to insure all exhibitors have fair and equal opportunities to market their products and services. A violation of rules will result in show management requiring the exhibitor to modify their exhibit to conform to advertised regulations. Expenses incurred to rectify a violation are the responsibility of the exhibitor.

Split Island Exhibit

Definition

A Split Island Exhibit is a Peninsula Booth which shares a common back wall with another Peninsula Booth.

Split Island Exhibit Height

The entire cubic content of this booth may be used, up to the maximum allowable height, without any back wall Line-of-Sight restrictions. The maximum height range allowance is 15 feet (15'). The entire cubic content of the space may be used up to the maximum allowable height. Double-sided signs, logos & graphics shall be set back ten feet (10') from adjacent booths.

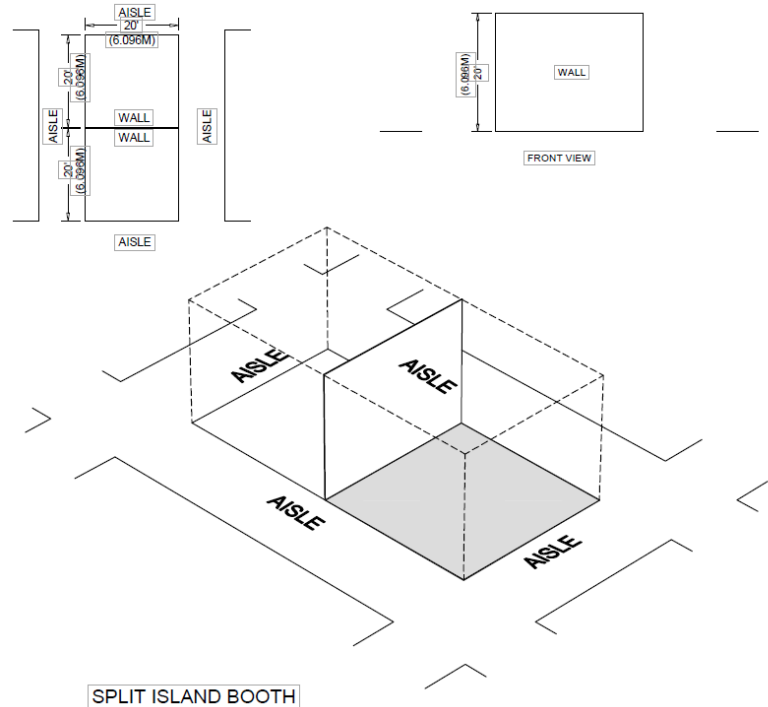

Show rules and regulations are intended to provide guidelines to insure all exhibitors have fair and equal opportunities to market their products and services. A violation of rules will result in show management requiring the exhibitor to modify their exhibit to conform to advertised regulations. Expenses incurred to rectify a violation are the responsibility of the exhibitor.

Island Exhibit

Definition

An exhibit with no adjoining neighbours and with two sides on the main aisle and two sides on the cross aisle. (Basically this is two Double Corner Units.)

Island Exhibit Height

Identification signs, canopies and displays will be permitted to a maximum height of 15' throughout the exhibit area.

Curtains & Displays

Exhibitors will not be allowed to place 15' high blocking curtains or side blocking unattractive displays along main traffic aisles.

Intent

Since an island booth is automatically separated by the width of an aisle from all neighbouring exhibits, full use of the floor space is permitted.

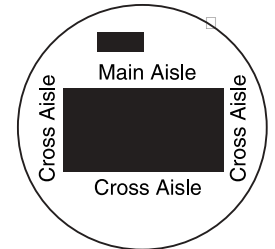
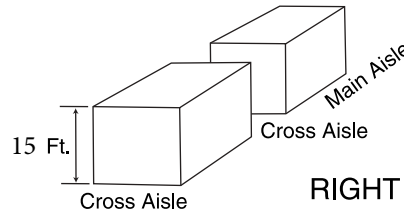
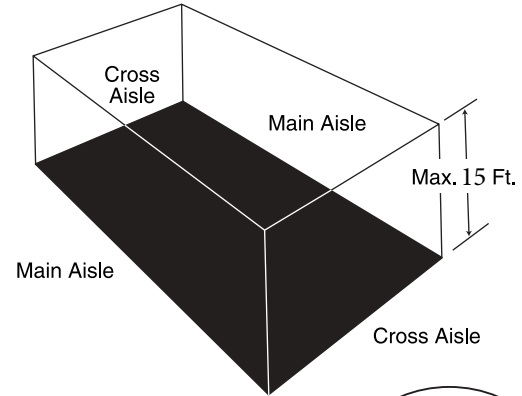

Show rules and regulations are intended to provide guidelines to insure all exhibitors have fair and equal opportunities to market their products and services. A violation of rules will result in show management requiring the exhibitor to modify their exhibit to conform to advertised regulations. Expenses incurred to rectify a violation are the responsibility of the exhibitor.

Double Corner Exhibit

Definition

Double corner exhibits have three open sides, two sides on the cross aisles and one large open side on the main aisle.

Height

All displays and equipment up to 15' in height are allowed anywhere within the double corner exhibit area because there is no adjacent neighbouring exhibit.

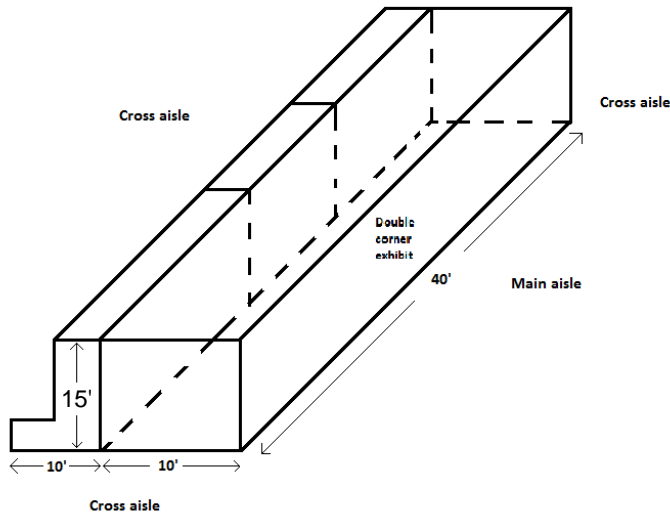

Show rules and regulations are intended to provide guidelines to insure all exhibitors have fair and equal opportunities to market their products and services. A violation of rules will result in show management requiring the exhibitor to modify their exhibit to conform to advertised regulations. Expenses incurred to rectify a violation are the responsibility of the exhibitor.

Hanging Signs

Please be advised that the ceiling height in the building is 15'. Signs will be hung to the maximum level possible. Minimum eligible booth size is 400 square feet for island, split island, peninsula, perimeter, and double corner configured booths.

Definition

An exhibit component suspended above an exhibit of four or more standard units back to back with an aisle on at least three sides for the purpose of displaying graphics or identification.

Height

Perimeter Booth: 15'0" (4.57m)

Peninsula Booth: 15'0" (4.57m)

Island Booth: 15'0" (4.57m)

Double Corner & Split Island Booth: 15'0" (4.57m)

Intent

Hanging signs are part of the overall exhibit presentation and, therefore, must be treated as a component of the total exhibit configuration. All signs, whether suspended or attached to the exhibit fixture, will be permitted to a maximum height that corresponds to the appropriate exhibit configuration.

Depth

All hanging signs must be set back at least 25% of the booth's width dimension from the backline of the booth.

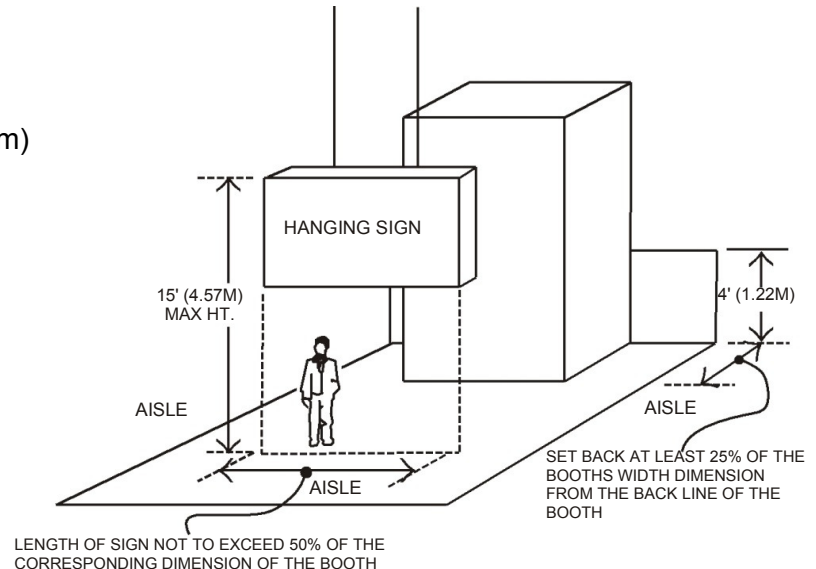

Structural Integrity

All hanging signs must have drawings available for inspection by exposition management, the installation and dismantling contractor, the exhibitor and governmental authority during the time the component is being hung, suspended and removed at the show site that include a signature or stamp of a reviewing structural engineer indicating that the stress points for hanging the sign have been properly engineered, and a signature of an authorized official of the exhibit building company indicating that the structure is built in compliance with the details and specifications set forth on the drawings.

(Note: exhibitors are encouraged to use lightweight materials in the construction of a hanging sign to eliminate excessive stress to the facility ceiling structure.)