

## Inline Exhibit

### Definition

An exhibit with neighboring exhibits on each side and faces only one main aisle.

### Exhibit Height

All display material over 4' high, placed within 10' of a neighboring exhibit, must be set back 5' from the main aisle.

### Intent

Each exhibitor is entitled to a reasonable sight line from the aisle regardless of the size of the exhibit. Exhibitors with larger space (30 lineal feet or more) should be able to effectively use as much of the total floor space as possible so long as they do not interfere with the rights of others. The limitation on display fixtures over 4' within 10 lineal feet of a neighboring exhibit is intended to accomplish this.

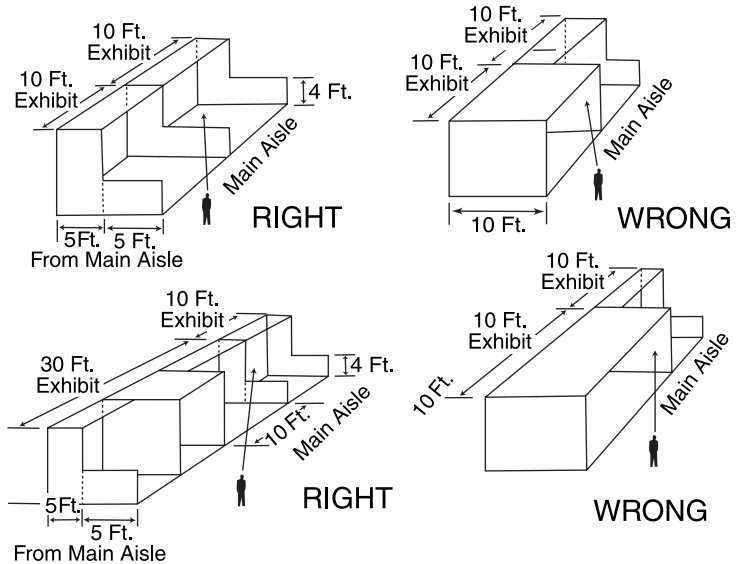
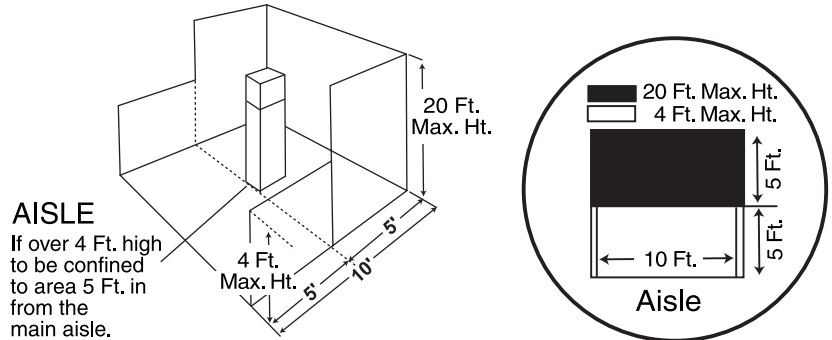

Show rules and regulations are intended to provide guidelines to insure all exhibitors have fair and equal opportunities to market their products and services. A violation of rules will result in show management requiring the exhibitor to modify their exhibit to conform to advertised regulations. Expenses incurred to rectify a violation are the responsibility of the exhibitor.

# Walk Through Exhibit

## Definition

An exhibit with neighboring exhibits on each side and faces two main aisles. (Basically two standard exhibits, back-to-back facing on two different aisles.)

## Depth

All display fixtures over 4' in height and placed within 10 lineal feet of an adjoining exhibit must be confined to that area of the exhibitor's space which is 5' from each main aisle. Back wall units may be displayed anywhere in the 20' height area.

## Intent

Each exhibitor is entitled to a reasonable sightline from the aisle regardless of the size of the exhibit. Exhibitors with larger space (30 lineal feet or more) should also be able to effectively use as much of the total floor space as possible as long as they do not interfere with the rights of others. The limitation on display fixtures over 4' and within 10 lineal feet of a neighboring exhibit is intended to accomplish both of these aims.

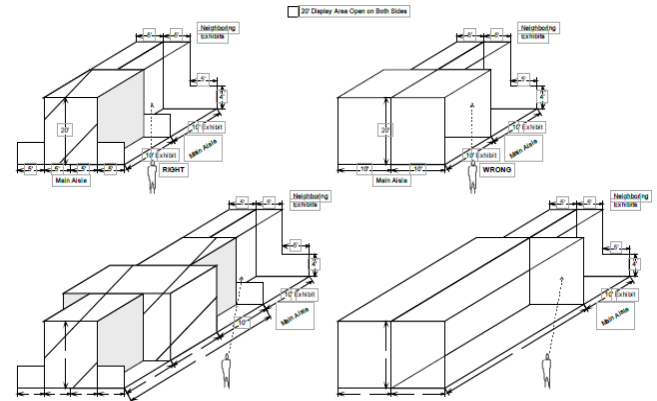
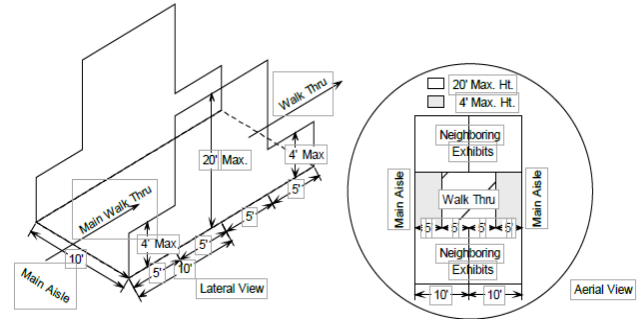

*Show rules and regulations are intended to provide guidelines to insure all exhibitors have fair and equal opportunities to market their products and services. A violation of rules will result in show management requiring the exhibitor to modify their exhibit to conform to advertised regulations. Expenses incurred to rectify a violation are the responsibility of the exhibitor.*

# Corner Exhibit

## Definition

A standard exhibit with at least 20' of main aisle frontage with an adjoining neighboring exhibit on one side and a cross aisle on the other.

## Exhibit Height

All display materials over 4' high, within 10' of the neighboring common side, must be placed 5' in from the main aisle.

## Intent

Exhibitors adjoining corner exhibits are entitled to the same reasonable sightline from the aisle as if they were not next to a corner exhibit.

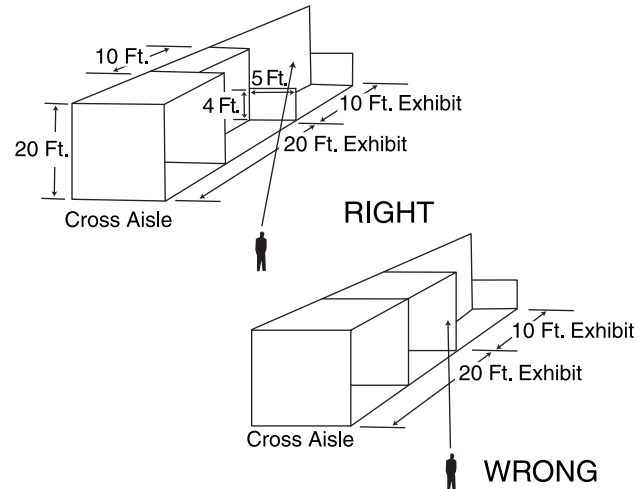

# Towers

If your exhibit includes towers with verbiage facing a neighbor or other display material (signs, balloons), over 8' tall, they must be placed at least 5' from the border between your booth and your neighbor.

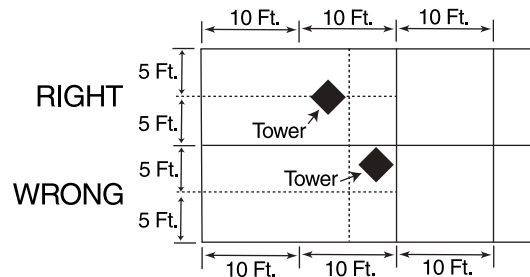

Show rules and regulations are intended to provide guidelines to insure all exhibitors have fair and equal opportunities to market their products and services. A violation of rules will result in show management requiring the exhibitor to modify their exhibit to conform to advertised regulations. Expenses incurred to rectify a violation are the responsibility of the exhibitor.

# Double Corner

## Definition

Double corner exhibits have three open sides, two sides on the cross aisles and one large open side on the main aisle.

## Exhibit Height

All displays and equipment up to 20' in height are allowed anywhere within the double corner exhibit area because there is no adjacent neighboring exhibit.

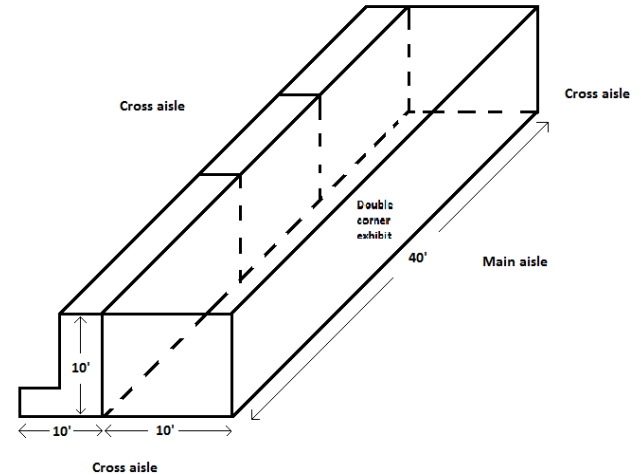

*Show rules and regulations are intended to provide guidelines to insure all exhibitors have fair and equal opportunities to market their products and services. A violation of rules will result in show management requiring the exhibitor to modify their exhibit to conform to advertised regulations. Expenses incurred to rectify a violation are the responsibility of the exhibitor.*

# Peninsula Exhibit

## Definition

An exhibit with three open sides, two sides on the main aisle and one side on a cross aisle.

## Exhibit Height

This type of exhibit must limit the length of back wall and placement of all displays over 4' high to 5' from the main traffic aisle (centered in the exhibit) and 10' from the neighboring exhibit. These items must be set back 5' from the main aisle and 10' from the border of the neighboring exhibit.

## Intent

Exhibitors adjoining peninsula exhibits are entitled to the same reasonable sight line from the aisle as they would expect if they were adjacent to an exhibitor with a standard exhibit.

## Curtains & Drapes

Exhibitors will not be allowed to place 20' high blocking curtains or side blocking unattractive displays along main traffic aisles.

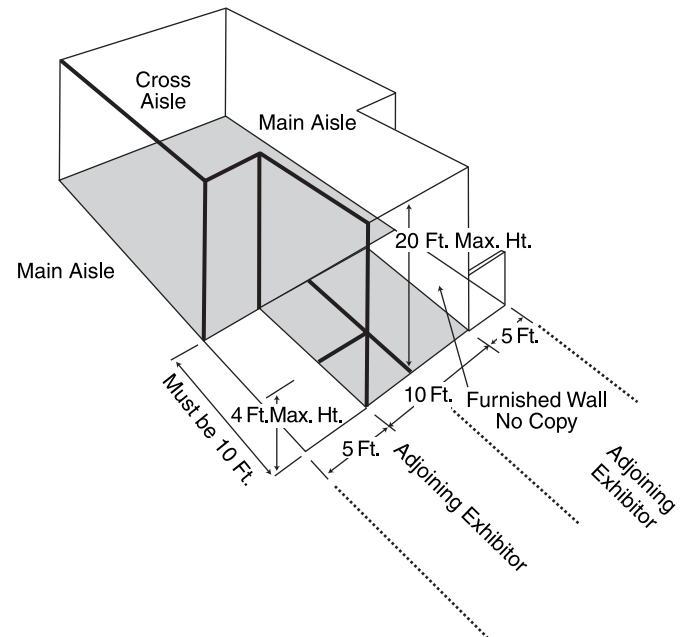
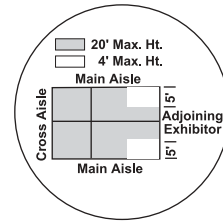

*Show rules and regulations are intended to provide guidelines to insure all exhibitors have fair and equal opportunities to market their products and services. A violation of rules will result in show management requiring the exhibitor to modify their exhibit to conform to advertised regulations. Expenses incurred to rectify a violation are the responsibility of the exhibitor.*

# Island Exhibit

## Definition

An exhibit with no adjoining neighbors and with two sides on the main aisle and two sides on the cross aisle. (Basically this is two Double Corner Units.)

## Island Exhibit Height

Identification signs, canopies and displays will be permitted to a maximum height of 20' throughout the exhibit area.

## Curtains & Displays

Exhibitors will not be allowed to place 20' high blocking curtains or side blocking unattractive displays along main traffic aisles.

## Intent

Since an island booth is automatically separated by the width of an aisle from all neighboring exhibits, full use of the floor space is permitted.

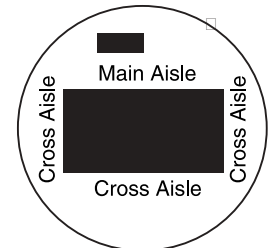
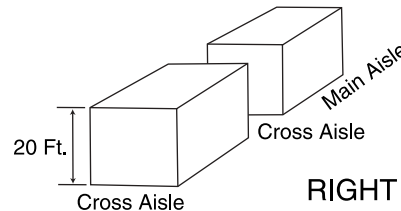
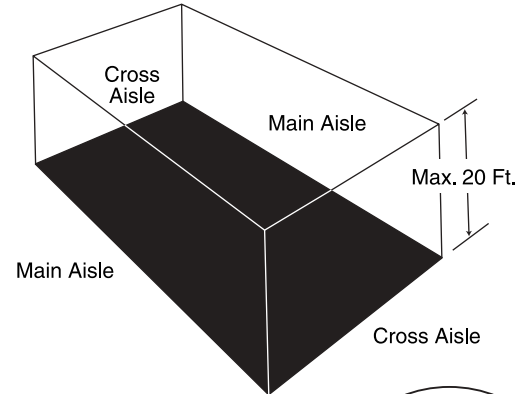

*Show rules and regulations are intended to provide guidelines to insure all exhibitors have fair and equal opportunities to market their products and services. A violation of rules will result in show management requiring the exhibitor to modify their exhibit to conform to advertised regulations. Expenses incurred to rectify a violation are the responsibility of the exhibitor.*

# Split Island Exhibit

## Definition

A Split Island Exhibit is a Peninsula Booth which shares a common back wall with another Peninsula Booth.

## Exhibit Height

The entire cubic content of this booth may be used, up to the maximum allowable height, without any back wall Line-of-Sight restrictions. The maximum height range allowance is 20 feet (20'). Double-sided signs, logos & graphics shall be set back ten feet (10') from adjacent booths.

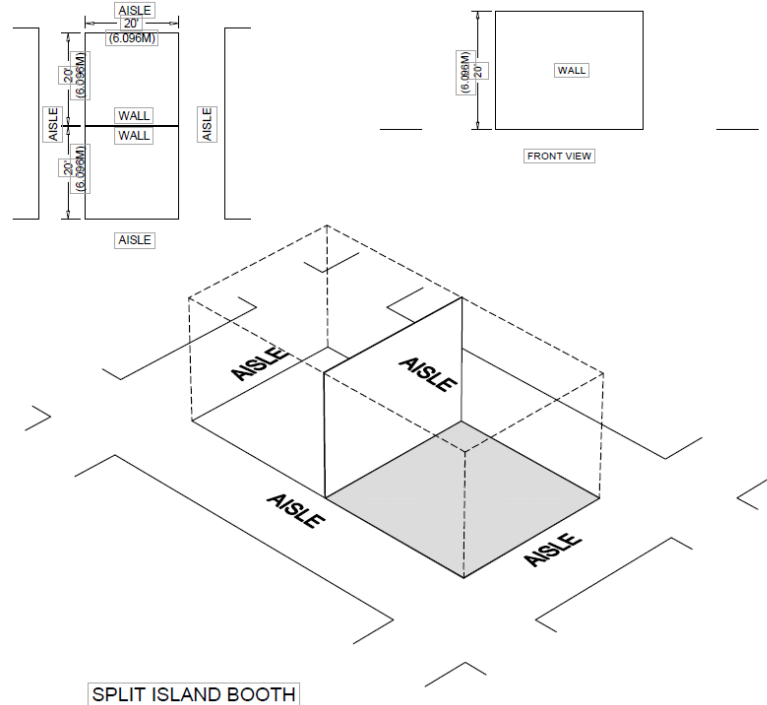

Show rules and regulations are intended to provide guidelines to insure all exhibitors have fair and equal opportunities to market their products and services. A violation of rules will result in show management requiring the exhibitor to modify their exhibit to conform to advertised regulations. Expenses incurred to rectify a violation are the responsibility of the exhibitor.

# Balloons

## Definition

Floor or exhibit mounted helium filled Balloons are permitted in all booth configurations. Helium filled Party balloons are not permitted on the show floor.

## Exhibit Height

The maximum height is 20' from the top of the balloon. Balloons must adhere to the 20' maximum floor structure height of the booth and are not to be hung at the maximum height of hanging signs. Balloons cannot be larger than 50% of the total booth depth. For example, a 20' x 10' inline booth can have a balloon up to 5' in diameter. Balloons should be set back 5' from adjacent booths if they are rotating or have text/graphics facing the adjacent booths and must remain directly over contracted space only. Approval for the use of Balloons, at any height, must be received from Show Management prior to installation. Variances may be issued at Show Management's discretion

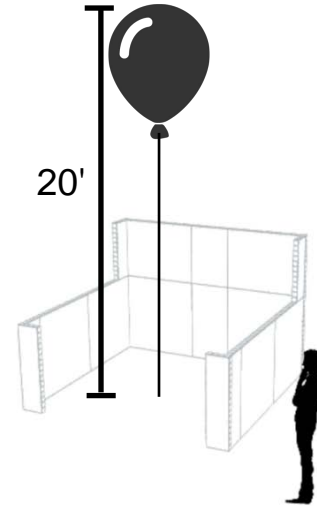

*Show rules and regulations are intended to provide guidelines to insure all exhibitors have fair and equal opportunities to market their products and services. A violation of rules will result in show management requiring the exhibitor to modify their exhibit to conform to advertised regulations. Expenses incurred to rectify a violation are the responsibility of the exhibitor.*



**April 8-10, 2025 | Huntington Place – Detroit, MI**

### **Hanging Sign Policies & Procedures**

Exhibitors desiring a hanging sign must adhere to the following conditions:

1. Hanging signs are only permitted for exhibit booths that are 400 sq. ft. and larger that are island, split-island, or peninsula configurations. Hanging signs are not permitted for inline or any other booth configurations. Companies occupying peninsula or split-island booths must position hanging signs at least five feet (5') from the back line of their neighboring exhibitor.
2. Hanging signs may be displayed at a maximum height of twenty-five feet (25') measured from the floor to the top of the sign.
3. Hanging signs must only be displayed within the confines of the exhibit booth boundaries and cannot be displayed over aisles, public space, and/or neighboring exhibit space.
4. All hanging sign materials and hanging framework (if applicable) must be shipped to the advance warehouse to be received between **Thursday, February 27 and Friday, March 21, 2025.**

RAPID + TCT / AeroDef 2025  
TForce Freight / JW Cole / Freeman  
6500 Mt Elliott  
Detroit, MI 48211

5. Hanging signs that require electricity must be in proper working order and be in accordance with the national electrical code. Order electrical services through the official general service contractor, Freeman. The discount price deadline date is **Thursday, March 6, 2025.**
6. All hanging signs must be installed by the official general service contractor, Freeman. See rules & guidelines in the exhibitor service manual for more information. Hanging sign ordering information and rules & regulations are available in the exhibitor service manual.
7. Rigged Structures - Freeman requires a stamped certification from a design professional (Civil or Structural Engineer) registered in the United States affirming structural integrity, calculations, and specifications for any custom-built suspended elements such as but not limited to signs, lightboxes, headers, video wall surrounds, and entry portals. For additional assistance regarding these requirements, please [contact us](#).

8. Tie-Offs - Freeman reserves the right to request a stamped certification from a design professional (Civil or Structural Engineer) registered in the United States affirming structural integrity, calculations and specifications and/or a peer review from such registered design professional for attachment of any structure to provide additional support terminating to the venue (Ex. Tie-off of header, seismic lines, tie-off of video walls). If you anticipate needing this service, please [contact us](#) for review and pre-authorization.
  
9. All hanging sign rigging plans must be submitted to Christopher Koval, [christopher.koval@freeman.com](mailto:christopher.koval@freeman.com), Freeman Rigging Manager, by **Friday, March 7, 2025**, in a DWG format.